

A Handy-Dandy Guide to Heaters

with

Information on the Causes & Corrections
of the Bad Things That Can Happen

◆

In the process of manufacturing tens of thousands of electric heaters for our pool, spa & jetted tub customers during the past few years. Aquatemp has seen and heard just about everything about the proper care and feeding of these units; and by paying a lot of attention to the details, we have acquired an excellent understanding of what can go wrong, and why. Also, our long, steady relationships with our suppliers, particularly with their engineering people, have provided us with an enormous supply of superior technical knowledge.

It seemed selfish to keep all of this good stuff to ourselves, so we have assembled this Handy-Dandy Guide to share some of that knowledge. One picture is still better than a thousand words.

Let us know what you think. We're interested in your comments, and welcome your input for future editions.

TM



PRODUCTS CORPORATION

1960 West 139th Street
Phone: (310) 225-3333
E-mail: service@aquatemp.com

Gardena, California 90249
Toll Free USA Fax: (888) 333-2FAX
World-Wide Fax: (310) 225-3322

Table of Contents

	page:
Anatomy of a Heater Element	2/3
Mechanical Failures:	
Broken End Seal	4
Broken Cold Pin	5
Noisy Operation	5
Dry Fire - The Ultimate Failure	6
Chemical Damage:	
Corrosion	8
Calcification	9
Weld Failure	10
Electrical Failures:	
Heating Coil Wire Open	11
Electrical Testing Procedures	12
Product Identification	14
Product Return Procedure	14
Warranty Policy	15
Out-of Warranty Policy	15
Ohm's Law Decoder Ring	Back

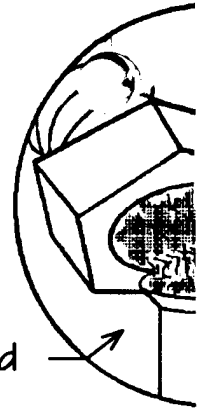

View of a broken
Terminal - to - Cold
Pin Weld

Electrical Terminal - to - Cold

Stainless Steel
Heater Housing

Bulkhead Threads

Heating Coil - 13



12

Incoloy Outer

Note: →

The numbers included with the call-outs, 12, 13 etc., in this drawing will be used as references throughout this Handy Dandy Guide.

The Anatomy of a

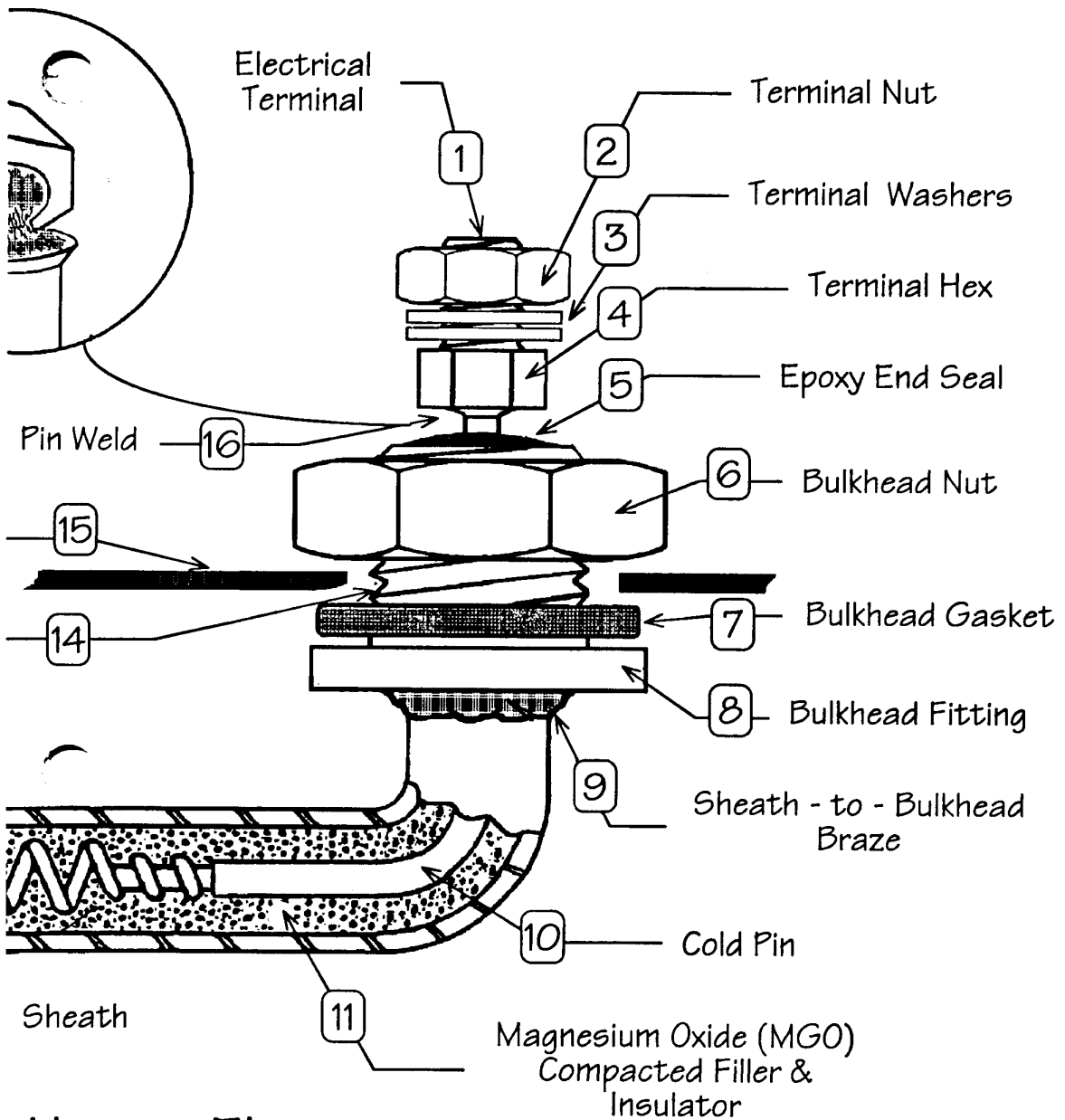

Heater Element

Mechanical Failures

The term "Mechanical Failure" covers everything from shipping damage to dog bite, but the most common mechanical failures in electric heaters are caused by improper handling - destroying the Epoxy End Seal (5), and breaking or twisting the Cold Pin (10) until it breaks are the two leaders in this failure mode. Because they are so closely related we'll look at them together .

WHAT HAPPENS?

Any form of rough handling can put pressure on the part of the heater that sticks out the most - the Electrical Terminal (1), which is welded to the Cold Pin, which in turn passes through the Epoxy End Seal to get to the Heating Coil (13) inside of the element. If the Electrical Terminal is broken away from the Cold Pin there is obviously no way to connect electrical wires to the heater, and it becomes a throw-away.

More often the rough handling results in the destruction of the Epoxy End Seal. This will allow moisture to get into the inside of the element where it will be absorbed by the MGO Filler (11) and will eventually cause an electrical short circuit between either the electrically "hot" Cold Pin or Heating Coil, and the electrically grounded Outer Sheath (12) of the heater. With luck, there will be a GFCI on the system that will open the circuit.

If you don't know what caused the GFCI to turn the power off, you might start investigating "nuisance tripping".

Without the GFCI there will eventually be arcs, sparks, flames and anger - you can bet on that.

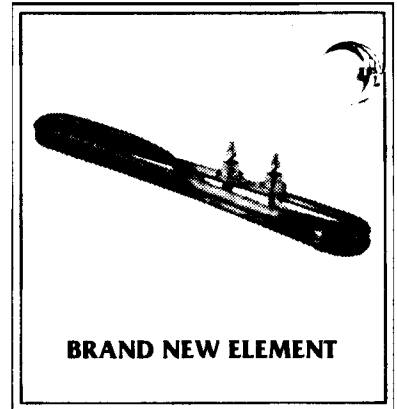

A Sidebar

When we talk about "Mechanical" failure we must remember that heaters have no moving parts. There is nothing to "wear out". There are no parts that spin, turn, jerk, or slide, and no gears to mesh, or hinges to squeak. All of the mechanical failures we can name are caused by people doing things they shouldn't do, or neglecting to do the things that they should do.

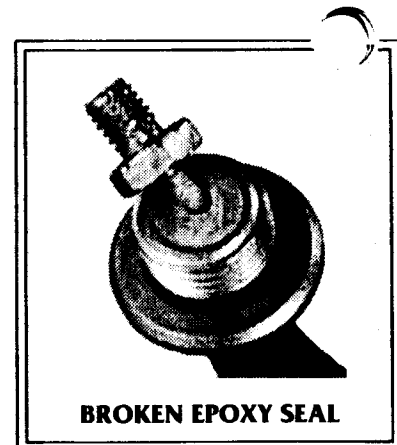

Mechanical, cont'd.

HOW CAN THIS BE PREVENTED?



Moisture may get inside of the element when it is off. Part of the cooling off process is to suck in any surrounding air through any crack. Then, the next time the element is energized, the moisture in the element may provide a path for current to flow, and the GFCI will trip. But, a BIG BUT - the heater may have been on just long enough to produce enough heat to drive that moisture out of there. You come along and reset the GFCI - and the heater will come back on again. Drive ya nutty, as they say. Check that Epoxy End Seal carefully.



Never bend, push, pull or twist the Electrical Terminal^①. Always use two wrenches to tighten or loosen the Terminal Nut^②. One wrench holding the Terminal Hex^④ to keep it from turning, and one on the Terminal Nut to do the tightening or loosening.

The trick to analyzing this failure is to carefully examine the Epoxy End Seal. Signs of severe fracture or chipping are an almost sure bet that the End Seal is no longer able to do its job - to seal. If the heater has been acting strangely - erratic - sometimes working fine and other times tripping the GFCI: look at that Epoxy End Seal.

THE NOISY HEATERS - HUMS, VIBRATIONS, SQUEALS, TWITTERS SHRIEKS, SCREAMS, RATTLES, WHISTLES, TWEETS, & CHIRPS

Rarely, maybe never, is the element itself at fault when noise is reported in a heater, even though it is the element that is usually making the noise. The huge amount of water moving rapidly past the element can set up some wild vibration patterns as it twists and turns through the heater. Usually it is simply a matter of re-aligning the element by a bit of gentle bending to move it away from the heater housing; or tying the noisy part down with a clip or wire made for the purpose. Check with us.

Dry Fire - the Ultimate

SETTING THE STAGE

In normal operation the heaters that we deal with daily in pools and spa operate at temperatures only a few degrees above the temperature of the water that is flowing past them. If the thermostat in a spa is set to maintain the water at 102°, for example, the temperature of the Incoloy Outer Sheath (12) will be about 110°. The water flowing past the element is carrying the heat away just about as fast as the element can produce it. Everyone is happy.

WHAT GOES WRONG?

One of three things can happen - A) the water flow slows down too much, B) the water flow stops, or C) the heater is somehow turned on with either no water in the housing, or only partially filled. The results will be the same: the Incoloy Outer Sheath temperature will rapidly rise - 200° - 500° - 1,000° - 1,500° in a matter of just a minute or two. This is approaching the melting point of the Sheath and it will get there quickly if it isn't turned off by some safety device like a high-limit switch. The failure can show up in several different ways:

- ✓ The Outer Sheath splits open. The Heating Coil (11) wire is hanging out in all directions and the MGO Filler (13) is cracked, smashed and blown away. The element is totally destroyed, and frequently the Stainless Steel Heater Housing (15) may be damaged as well.
- ✓ Just one or two small holes are blown through the Sheath - not as dramatic as a complete, explosive meltdown, but just as costly. The element is destroyed.
- ✓ No holes are visible, but the walls of the Sheath are bulged outward in spots. The normally smooth surface of the Sheath is now bumpy and has become discolored. Inside of the element the Heating Coil may be broken; or it might be electrically shorted against the Sheath. Or both.



Element Destroyer

WHY? WHY? WHY?

Another Sidebar

During the manufacturing process the element ends up with a black chromium oxide coating that gives it that dark overall coloring, almost like gun bluing. A side benefit of this coating is that it acts as an excellent indicator of the element being operated at too high a temperature. Any time you see a change in the color of that black oxide coating - ranging anywhere from multi-colored, rainbow-like colors to dull shades of light gray or even brown, it's a guarantee that the element has been allowed to operate far, far above its intended operating range.

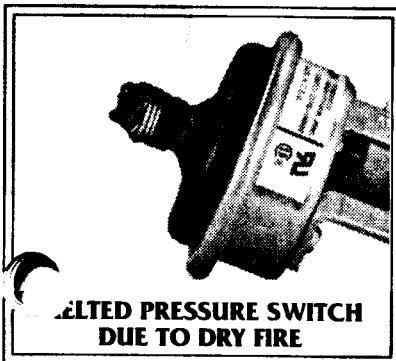

MELTED PRESSURE SWITCH
DUE TO DRY FIRE

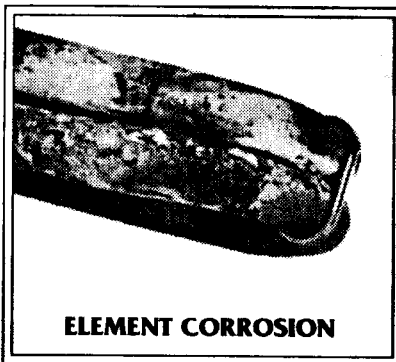

ELEMENT CORROSION

That's three good questions. Let's take a look at a few of the things we have learned from a lot of field experience plus a ton of hours in the engineering lab:

HIGH LIMIT PROTECTION - the primary job of the High Limit Switch in the finished product is to prevent scalding water from ever reaching the people using the product. Sure, the Thermostat should shut the heater off long before the point at which the High Limit Switch is needed, but Thermostats, like everything else, fail.

Will the High Limit do its job? It hasn't had to operate for months or years - is it ready? Is it in the right place to do the job? If the High Limit is not sensing the water temperature close to the element, and the pump suddenly quits - it's dry fire time in just a minute or two. The element will boil the water in the heater housing - and create its own "dry" condition.

Following that, the service technician arrives and finds the heater assembly full of water again, and claims it couldn't have been a dry fire. Check that High Limit.

FLOW/PRESSURE SWITCHES - various types of devices are used to detect whether there is any water flowing through the heater assembly. Unfortunately, when these things fail, they generally fail in the *closed* position and there is no indication that they are not doing their job. In most cases a spa system will work just fine with a stuck pressure or flow switch - until there is a need for it.

If a full-scale dry-fire destroys the flow or pressure switch along with the element, it's impossible to determine which went first; but one thing is certain - the heater was doing its job. It isn't very smart - it just makes heat.

Attack of the

CORROSION - the Bad Guy

It's a mean, angry sounding word, bringing visions of all sorts of na things. Even the dictionary makes it sound pretty evil "...akin to RODENT no less. Come to think of it, we've seen a few heaters that looked like rats had been gnawing on 'em.

cor·rode (kā rod') v.

1. to eat or wear away gradually as if by gnawing, esp. by chemical action
ME (<MF) <L corrōdere to gnaw; akin to RODENT

We think it's a safe bet to say that one of the major causes of heater failure has always been corrosion. Given any chance at all, this demon will destroy a heater element or, in many cases, the entire heater.

The corrosion we come across in our industry, particularly in spa equipment, comes in many varieties, each with its own name and characteristics - we are faced with galvanic corrosion, chemical pitting, intergranular corrosion, stress corrosion cracking, corrosion fatigue, electrochemical corrosion - we even have a strain of bacteria: *Ferrobacillus* in the *Siderocapsaceae* family, also called "iron eating bacteria," to contend with. Gee Whiz.

WHAT CAUSES ALL THIS ?

Well, a full discussion of the chemistry and electrochemistry involved with this pretty complex subject is beyond the intent of this Handy-Dandy Guide. It's much easier to describe what *doesn't* cause it than to attempt to explain all the chemistry that *does*. Consider this: if all those spas out there were filled with clean, pure water, and no one ever added any chemicals to them, the word corrosion would soon leave our vocabulary.

Unfortunately, that's not going to happen, and all those spas are going to continue being filled with water of every type, from the Cascade Mountain's rain water to big-city sludge.

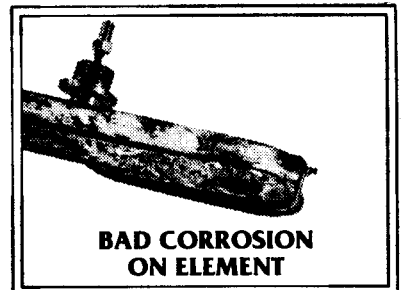
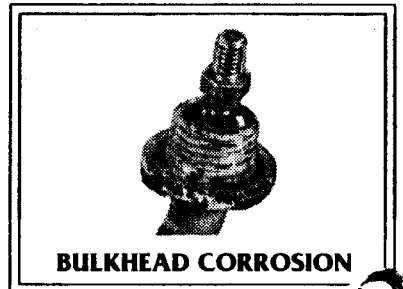

Miller Chemicals

A DEADLY SOUP

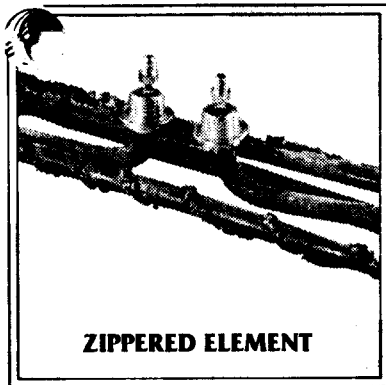

Then, to add to the problem, we have learned that many, many spa owners are not following all of the instructions they've been given about pH, Total Alkalinity, Calcium Hardness and Total Dissolved Solids; or about how to handle those unique water problems that may exist in their spa when it is filled with water from their tap.

LOW pH - BOO! HISS!

If we had to pick the worst offender in the corrosion list, it would definitely be LOW pH, because, as we all learned long ago: when a test sample of the water shows a LOW pH (below 7.0), it indicates the water is **ACIDIC**. Remember now, this is not just saying that there is **ACID** in the water - it says that the water has become an **ACID**. It doesn't matter at all what kind of **ACID** caused this to happen - hypochlorous, hydrochloric, hypobromous, muriatic or whatever - when the water becomes an **ACID** it becomes a starving, hungry, corrosive beast looking for lunch. **ACIDS** will corrode - eat away - almost any metal in their path in order to satisfy that hunger.

An element or heater corroded because the water has a LOW pH is easy to spot - it has pieces eaten away from its surface. Gone, disappeared, departed. It looks like the craters of the moon. And people are putting  bodies in there!

SCALE / CALCIFICATION - HISS! BOO!

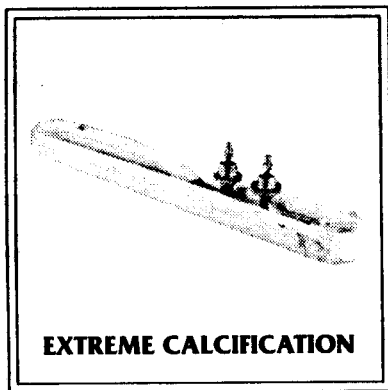

At the other end of the ----- we have SCALE. In some ways SCALE can be considered as the opposite of **ACID**: with SCALE the water has too much of something and wants to get rid of it, and the nice warm heating element is a good place to deposit it. The problem is that it's like asking a Hawaiian to run a marathon in Honolulu dressed in a fur coat, wool cap and mukluks. He's going to have a rough time getting rid of the heat he's generating, and probably won't finish the race.

and then again.....

MORE UGLINESS

Bad-chemistry corrosion can show up where the element sheath is brazed to the bulkhead fitting, or welded to a mounting plate. Even though all the parts are "stainless" steel, and selected just for this purpose, the ingredients (mostly iron, chromium, nickel and molybdenum) in the steel must vary - the mix has to be different for parts like the Bulkhead Fitting⁽⁸⁾ that needs to be machined, versus the thin, high temp Incoloy Outer Sheath⁽¹²⁾ that must be bent and formed.

Very special welding techniques are used at these joints to make sure that no impurities are left behind that might corrode. But, if the water gets bad enough, you may see corrosion at these weld points. It can range anywhere from a rust-like deposit to cracks and fissures in the metal.

At its worst it can result in "corrosion fatigue," causing the Bulkhead Fitting to break away from the Outer Sheath. This corrosion is bad stuff.

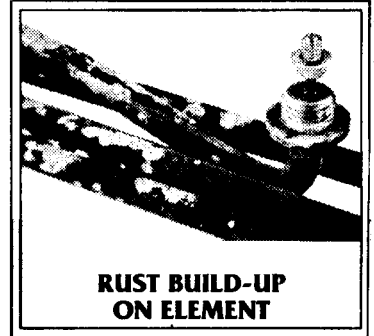

AND THEN: THERE'S THE IRON EATER

A slippery, brownish coating on the inside wall of a spa may not be any form of algae, but can be the effects of an "iron eating bacteria" that is gnawing away at the heater. This one is easy to correct - the water simply needs some sanitizer: chlorine, bromine or ozone. A "shock" treatment would probably be in order here, a drain and refill if it won't go away.



WHAT'S THE BOTTOM LINE ON CORROSION?

Corrosion of the metal in a pool or spa heater happens when the water becomes corrosive because somebody makes mistakes with its chemistry.

There are more than 2,000,000 spas in the USA alone that have never shown any signs of corrosion - some more than twenty years old.

Their owners follow the instructions of the professionals at their local pool/spa store, and maintain a good sanitizer level along with a non-corrosive pH level, and monitor their Total Alkalinity, Calcium Hardness and Total Dissolved Solids for a good water balance. They do not "Throw in a little of this or a little of that." That's like signing a Pledge Of Corrosion.

Electrical Failures

DO THEY EVER JUST "BURN OUT" ?

It is correct to say that the only "natural" - like in "died of natural causes," - electrical failure that a resistance-wire heater ever suffers is when the Heating Coil⁽¹⁾ breaks, causing an OPEN in the circuit. This is also the only electrical failure ever covered by our warranty.

It's exactly the same as a light bulb burning out - it just gets tired of the tremendous trauma it goes through each time the power is applied. Picture it - it goes from cold to very, very hot in less than 1/10th of a second - it opens its door to see who's knocking and a thousand billion billion electrons (that's 21 zeros!) rush in during the first second.

Because of the careful selection of components in the Heating Coil, this sort of failure is actually quite rare. (Have you every seen a light bulb burn out while it was on? Probably never - they always burn out just as you turn them on. That's "turn-on trauma".) However, it can be brought on more quickly by switching the heater on and off rapidly - this can happen with a defective control, such as a chattering contactor or thermostat, for example. Be very suspicious if a replacement heater burns out quickly. Watch for this.

Another suspect in an OPEN situation is a reduced water flow that causes the element to operate at a much higher temperature than normal, but not high enough to cause a dry-fire condition. There may be no signs of the problem on the outside of the element - it just got tired of working too hard.

A Special Note To Our Manufacturer and Assembler Customers:

Please remember that both Aquatemp and the original manufacturer of the heater element have run the required Dielectric Voltage Withstand Test ("Hi Pot Test") on every unit we build. Both of us are very careful to keep the test time to the absolute minimum allowed to prevent any degradation of the dielectric material within the element. We strongly urge you to do the same.

Everything You Always Testing of the Electric

THEY'RE SIMPLE - REALLY

Of any piece of equipment you might find on a spa or tub today, the electric heater is probably the most simple - we're not talking here about the controls, now - just the heater itself. What makes it simple is that it is a straight resistive device. It doesn't have any coils like motors and transformers, giving them inductive characteristics; and it isn't anything at all like a solid state, printed circuit board mounted, micro-processor based control system. With heaters, the electrical is plain-Jane.

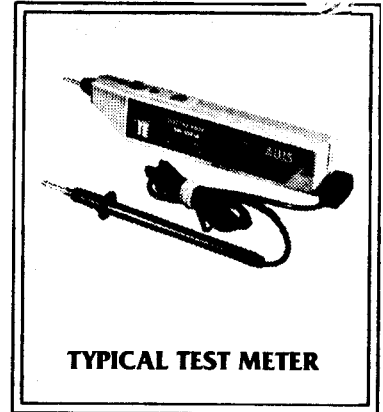

TYPICAL TEST METER

THE IMPORTANT NUMBERS

You can learn just about all there is to know about an electric heater by applying a little knowledge and a smidgen of easy math, along with a decent test meter. We'll start with the basic numbers:

- ⊙ These first two numbers are stamped or marked on the heater .
 - Rated Voltage, like: 115, 120, 240, or 230 volts
 - Rated Wattage, like: 1500, 5500 watts or 5.5kW
- ⊙ These next two are calculated using the above numbers:
 - Calculated Amperage, like: 12.5, 22.9, 25, or 48 amps
 - Calculated Ohms, like: 5.0, 9.6, or 10.5 ohms

The math part is kept simple by using our Handy-Dandy Decoder Ring, shown to the right. Let's say you want to figure the amps rating of a heater marked 240 volts & 5500 watts. Use $\frac{W}{V}$: that would be 5500 divided by 240, and the answer is 22.9 amps. Simple. (We know you're going to use our HDDR a lot, so we put a larger version on the back cover of this Handy-Dandy Guide You're welcome.)

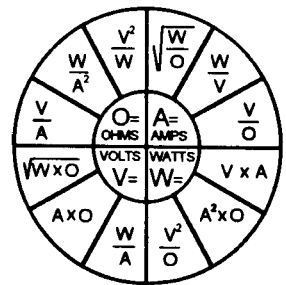

- ⊙ The next three are measured with a meter at an operating heater:
 - Measured Voltage, like: 112, 227, or 238 volts
 - Measured Amps, like: 11.5, 21, 24.6, or 44 amps
 - Measured Ohms, like: 10.4, 9.6, or 4.9 Ohms

Wanted to Know About Part of Electric Heaters

USING THE NUMBERS

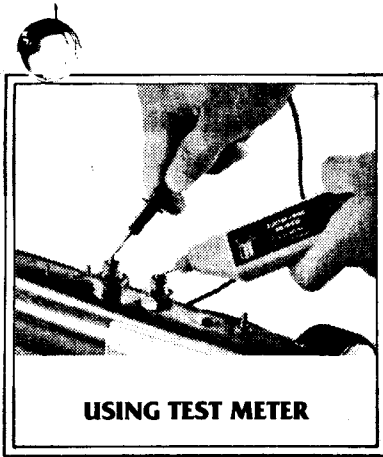

All that follows applies to all electric heaters. The task is simple - to determine if the heater is producing heat (watts); and then make sure that it is safe - these are the facts, ma'am.

© First, measure and compare the voltage at the heater terminals with the voltage at the panel board, receptacle or other power source. Don't blame the heater for poor performance if this Measured Voltage is more than 10% below the heater's Rated Voltage. (Do the math $\frac{V^2}{O}$, to see how quickly the watts drop as volts drop.)

© If the Measured Voltage was much different than the Rated Voltage, you'll have to re-figure the Calculated Amps using $\frac{V}{O}$. (You can't use $\frac{W}{V}$, because you're not sure what the wattage is anymore.) Then, with power still on, put your clamp-on ammeter around ONE of the heater wires - either one, but only one. You're now reading Measured Amps, which should match the Calculated Amps number, within 10%.

© Turn OFF all power, then DISCONNECT BOTH WIRES from the heater terminals. Set the meter to the OHM's scale and take the following readings at the element terminals:

☞ Terminal - to - terminal: the Measured Ohms should read within 10% of Calculated Ohms.

© From each terminal, one at a time, to the element sheath or element mounting plate: should read OPEN or INFINITY. ANY OTHER READING says the element is internally shorted. This is a bad element. Look for signs of dry fire damage.

That's it. You now know all there is to know about the electric stuff in the heater. You can now re-calculate the wattage using the voltage, amps and ohms numbers you have measured, confident in your knowledge.

The Meter Sidebar

A good test meter is a must if we are to learn what's going on in the electric heart of that heater. Take full advantage of today's technology and check out the latest units that combine the digital volt/ohm meter with a clamp-on ammeter. It's like they knew about electric heaters when they designed these guys. Check out B&K Precision's 330 & 340; A.W. Sperry's DSA-2007, and others by Radio Shack, Fluke and Scope. All are available in the \$80 - \$100 range.

Product Return Procedures

All products to be returned must be pre-authorized for return or the return will not be accepted. To obtain authorization, simply contact Aquatemp by any of the following ways:

USA Toll Free FAX
World-Wide FAX
Telephone

1-888-2FAX-888
1-310-225-3322
1-310-225-3333

Mon - Fri,
8AM to 4:30PM PT

E-mail

service@aquatemp.com

Request a Return Material Authorization (RMA), indicating exactly what it is you wish to return, the quantity, and the reason for the return. An RMA will be assigned and FAXed (or mailed) to you.

Package the items sufficiently to prevent shipping damage (shipping damage on items being returned is not covered by warranty).

Include a copy of the RMA Document inside your package, and print the RMA number plainly on the outside of the package. Prepay the shipping charges - COD or Freight Collect shipments will not be accepted.

Ship To: Aquatemp Products Corporation
1960 W. 139th Street
Gardena, CA 90249

Once the goods are received they will be inspected and repaired, replaced or credited as per your instructions; or as our Limited Warranty deems appropriate.

Allow up to 30 days for repair or return of items unless specific arrangements have been made otherwise.

We will pay the shipping charges to return the repaired or replaced items to you at standard UPS surface rates, or equivalent.

⌘

Identification of Aquatemp Product

All Aquatemp heaters and heater elements are date coded by either a label on the heater housing, or by stamping directly on the element as follows:

Heaters - Label Code Word: "CHARLESTON", where C=1, H=2, A=3, F=4, etc. So, when the label has a Date Code of: NLHTOE, it means that the heater was manufactured on 05/28/96 - May 28, 1996.

Elements - Stamped directly into the element sheath is a single letter code where G=1991, H=1992, ("I" was not used,) J=1993, K=1994, L=1995, M=1996, etc.; followed by a single numeral from 1-4 indicating the quarter of the year during which the element was manufactured. So, if "K4" was stamped into the element it would indicate that the element was manufactured during 1994, in the fourth quarter of that year.

Aquatemp Products Corporation Heating Products Limited Warranty

Aquatemp Products Corporation (Aquatemp) warrants to every original purchaser of Aquatemp's spa, pool, and bath tub heating products, that the product will be free from defects in materials and workmanship for either: a period of not less than eighteen months after the manufacture date, or for a period of not less than twelve months after installation, whichever occurs first.

If, at any time during the Limited Warranty period, defects in Aquatemp's workmanship or manufacturing materials prevents the product from performing correctly in an application for which it was designed, Aquatemp will repair or replace the product, as Aquatemp deems appropriate, at no charge to the original purchaser for Aquatemp's labor, parts or materials used in accomplishing these repairs or replacements.

This Limited Warranty does not provide for any repair or replacement of products which have been subjected to any form of abnormal operation, including, but not limited to: electrical or mechanical abuse, the negative effects of improper water chemistry that others do not properly control, dry fire, improper use or application, or anything else that someone other than Aquatemp does, or fails to do, which causes failure of the product.

This Warranty is Limited in that it does not cover any monetary reimbursement for freight charges, or for removal and/or installation labor, or incurred costs by any other persons or firms, including (but not limited to) any consequential damage or loss of use that might be claimed.

Repaired or replaced products will have the unused remainder of the original Limited Warranty period as their Limited Warranty. However, if less than 120 days remain before the expiration of the original Limited Warranty, the expiration date of the original Limited Warranty shall be extended for a period of 120 days from the date that the repair or replacement is completed.

This Limited Warranty gives you specific legal rights, and you may have other rights which vary from state to state.

Aquatemp's Out-of-Warranty Policy

Even though we have a formal Limited Warranty, as shown above, and follow what it says very carefully, we feel that it is appropriate to have policies and procedures in effect to take care of our customers needs in those cases where an item has failed for reasons not covered by the warranty; and for anything that occurs after the Limited Warranty period expires.

It's simple - we will repair any item that is still within the Limited Warranty time period, but which has a defect that is not covered under the Limited Warranty, without charging any labor costs to our customer. We will charge only for the cost of the parts required to make the product like new again.

If the warranty period is over, we'll still try to do the right thing by repairing any of our products for a flat \$5.00 labor charge, plus the cost of the parts.

And, in both instances, we will prepay the UPS surface freight to get the items back to you. Fair enough?

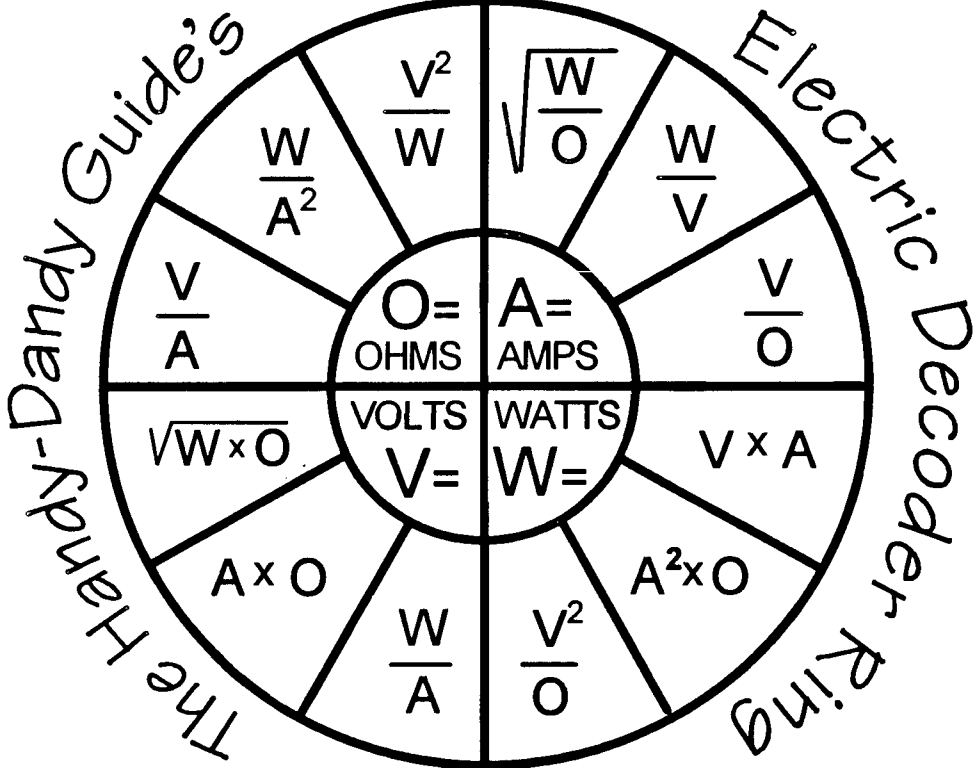

MR. OHM'S LAW

A relatively simple principle, Ohm's law states that if one volt produces a current of one ampere through some conducting pathway, then the resistance of that pathway must be one ohm. The mathematical formula resulting from this is:

$$O = \frac{V}{A} \quad \text{or:} \quad \text{OHMS} = \frac{\text{VOLTS}}{\text{AMPERES}}$$

We can move the terms around to suit our needs:

$$V = A \times R \quad \text{or:} \quad \text{VOLTS} = \text{AMPERES} \times \text{OHMS}$$

$$A = \frac{V}{R} \quad \text{or:} \quad \text{AMPERES} = \frac{\text{VOLTS}}{\text{OHMS}}$$

Think of it this way: the **volt** is the force (*the pressure*) that pushes the **amp** (*the current*) through the **ohm** (*the resistance*), and the **watt** is the measure of *the work* that is accomplished in the process.

Produced by AQUATEMP PRODUCTS CORPORATION

Designers, manufacturers & purveyors of a broad line of equipment for the swimming pool, spa and jetted bath industry.

This Handy-Dandy Guide is copyrighted, and may not, in whole or part, be copied, reproduced, reduced, enlarged or translated by any means: mechanical, electronic, photographic or other, without prior express written consent from Aquatemp Products Corporation.